

Industrial machinery and heavy equipment

Pentair

Flow control manufacturer uses Solid Edge and Femap to improve assembly efficiency by more than 20 percent

Products

Solid Edge, Femap

Business challenges

Achieve a more efficient design process
Improve product safety
Enhance assembly efficiency
Seamlessly manage various data formats

Keys to success

Use Solid Edge CAD software for product development
Use Femap FEA software to optimize design

Results

Significantly improved design process efficiency
Realized optimal design throughout the entire product family
Improved workshop assembly efficiency by more than 20 percent
Dramatically reduced the number of product complaints
Enabled quick answers to any questions from downstream manufacturers

Siemens PLM Software solutions enable Pentair's Valves & Controls business unit to significantly enhance design quality and processes

Finding a perfect match

Pentair's Valves & Controls business unit is its largest, producing valves, actuators and flow control products. Pentair is a global leader in this domain and provides services and solutions for the most challenging applications across a variety of industries, including oil and gas, power, metallurgy and chemical. With a wealth of expertise accumulated over 140 years and more than 900 technology patents awarded in recent years, Pentair delivers vital infrastructure to local communities around the globe.

In China, Pentair's Valves & Controls business unit has established a comprehensive, efficient and fast-operating system that integrates manufacturing, sales, inventory, assembly, maintenance and service. Its Product Automation Center is representative of similar branches of Pentair across China.

Pentair's Beijing Product Automation Center bought licenses of Solid Edge® software primarily for the design of electrical accessories that are needed when making valve controls, fittings and actuators, and for drafting 3D assembly drawings according to assembly or bidding requirements.



In comparison to other heavy machinery manufacturers, the center's business involves low repeatability for products and high repeatability for parts, with the combination of different product parts leading to a high volume of finished output.

Solid Edge, from product lifecycle management (PLM) specialist Siemens PLM Software, is highly suitable for Pentair's Beijing Product Automation Center in terms of scale and business scope. Solid Edge, which utilizes Windows® software, has a user-friendly interface. It is particularly advantageous to mid-end users who want their software to be easy to use and fast to operate, and who need to accommodate extensive design variations.

Results (continued)

Completed secondary development of the quotation system
Unified design and purchase cost calculation process

“I am not particularly worried if corporate requires us to change the system since we have very clear and strong data management, adaption and transformation capabilities with the help of the integrated Solid Edge and SAP solution.”

Xie Ke
General Administrator and
Warehouse Manager
Product Automation Center
Beijing Office
Pentair Valves & Controls
Corporate China

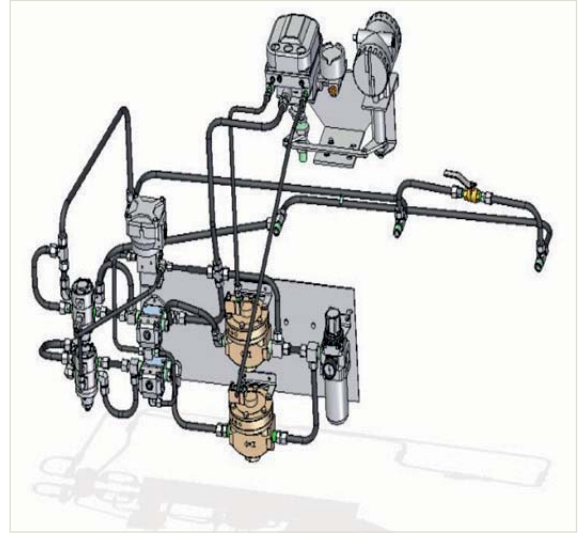
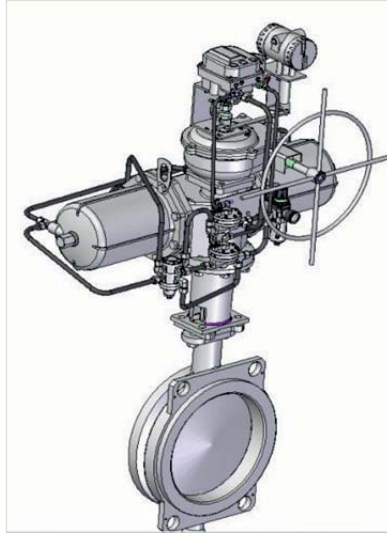

According to the management of Pentair's Beijing Product Automation Center, Solid Edge is a perfect match, both functionally and operationally.

“We wanted design software that was more user-friendly instead of a static unengaging tool,” says Xie Ke, general administrator and warehouse director at the Product Automation Center, Beijing Office, Pentair Valves & Controls Corporate China. “Solid Edge is that software; it makes our work much easier.”

Enhancing the platform

Apart from product design, Pentair's Beijing Product Automation Center has five business functions, including parts purchasing, planned production, product assembly, quality inspection, and warehouse management. The center's product quotation system, which was customized to fully leverage Solid Edge, combines parts purchasing and planned production.

Using the center's product quotation system, purchasing team members can directly enter all supplier/cost information into the system and combine the data with the parts library, enabling them to easily and quickly produce a quotation. The intuitive system significantly simplifies cost

estimating as well as accelerates design approval. The team plans to further develop a costing system to realize additional cost savings.

Prior to the deployment of Solid Edge, Pentair's Beijing Product Automation Center had used 2D drafting software for product design. The plain, three-view drawings produced using the 2D software are not detailed, negatively impacting designer efficiency and assembly worker productivity.

Xie Ke explained, “Using 2D drawings for the shop floor assembly process poses greater demands on operators. They must be able to read and understand the drawings, but the problem is that not all assembly workers are equipped with the same skill sets as designers. However, with Solid Edge, the operators see a 3D model of the product, which provides a more intuitive and thorough understanding of the product and helps them work faster and smarter.”

An easy-to-understand 3D model also plays an important part in helping advance product sales. Xie Ke notes that when a salesperson is displaying a product to customers, a 3D model helps the representative better illustrate the benefits of the product.

Advancing design integrity through FEA

Xie Ke explains Pentair's introduction to Siemens PLM Software's Femap™ software: "When we first started to use Femap, it was to address a question a sister company had about a product of ours. We were working on the design of a fitting product. After the product was finished, the sister company in charge of implementation told us that they were disappointed with our product; that they had some problems with installation."

After some discussion with sister company representatives, Xie Ke learned that they were now working on the design of a similar product; however, the fitting designed by Pentair was slightly different from the new one in terms of shape and parameters, so they were concerned about whether Pentair's product could adequately bear the stress and torque force. Under such circumstances, Xie Ke was uncertain of what to do to address the question or how to prove his own product.

"Back then, our products were completely based on designer experience," says Xie Ke. "We didn't have advanced design tools, and we didn't conduct analysis and verification on our products. What I could give them at that time was that we had always relied on experience and had not encountered any problems over the years. But of course, they wouldn't buy that."

The incident made Xie Ke realize that a design approach based on personal experience, while exceptional, would no longer sufficiently meet the enterprise's design requirements, and the company needed to approach design data management on a larger scale. He also realized that dynamic product performance analysis was needed in order to improve product design and the research and development (R&D) process.

Having some experience with finite element analysis (FEA) software and computer-aided engineering (CAE) technology, Xie Ke believed that implementing FEA earlier in the product R&D process – to analyze and verify the product and thereby optimize the design – was an effective way to change from passively answering a client's questions to proactively having answers to any questions that a customer might have.

After a comprehensive assessment of a variety of relevant analysis software, Xie Ke chose Femap for two primary reasons. First, Femap is part of the Siemens PLM Software product line and, therefore, it can be seamlessly integrated with Solid Edge, which has been used by Pentair's Beijing Product Automation Center for a long time. This meant that Pentair could secure a comprehensive conversion of features without losing any of them, and

"Using 2D drawings for the shop floor assembly process poses greater demands on operators. They must be able to read and understand the drawings, but the problem is that not all assembly workers are as capable as designers. However, with Solid Edge, the operators see a 3D model of the product. The 3D representation provides the operators a more intuitive and thorough understanding of the product, and ultimately helps them work faster and smarter."

Xie Ke
General Administrator and
Warehouse Manager
Product Automation Center
Beijing Office
Pentair Valves & Controls
Corporate China

"We wanted design software that was more user-friendly instead of a static unengaging tool. Solid Edge is that software; it makes our work much easier."

Xie Ke
General Administrator and Warehouse Manager
Product Automation Center
Beijing Office
Pentair Valves & Controls Corporate China

Solutions/Services

Solid Edge

www.siemens.com/solidedge

Femap

www.siemens.com/plm/femap

Customer's primary business

Pentair (Valves & Controls business unit) is one of the world's leading manufacturers and marketers of valves, actuators and controls. It provides products, services and solutions for challenging applications in the oil and gas, power, mining, chemical, food and beverage, and building and construction industries.

valves.pentair.com

Customer location

Yizhuang Development Zone

Beijing

China

complete the entire cycle of design/verification/design. Second, Femap is easy to learn and use, making it practical for most of the organization's engineers to simulate and analyze their own projects. In fact, engineers were able to use Femap independently in short order.

Xie Ke notes, "Use of Femap gives a great boost to our design efficiency and final product quality." According to Xie Ke, Pentair's Beijing Product Automation Center introduced Femap in June 2013, and started to do analysis and verification on a large number of products. The use of Femap not only enabled engineers to analyze the various running states of a product after installation, but it also allowed designers to intuitively comprehend the relation of stress between controls and valves. They were able to verify whether the product is safe and able to bear certain deformation forces or whether the product might fail under different conditions of

stress, temperature and atmospheric environmental impact.

The FEA strengths of Femap can be used to check any quality issue that has a direct impact on the product performance; it can also help with design optimization and improvement. With Femap, Pentair's engineers now understand the product they're designing both in terms of breadth and detail. This gives them a clear view of the overall product's structural integrity as well as the stress condition of every component. Using Femap, the engineers see all parts of the design that do not have sufficient bearing capacity, and they recognize redundant structures in which excess materials are used. Ultimately, using Femap, the engineers analyze, verify and optimize the design on those structures, thus significantly improving product quality and reducing the cost of production.

Based on the finite element analysis and verification of designed products, Pentair's Beijing Product Automation Center has essentially eliminated product-related complaints and rework, and comprehensively addressed any issues of misgivings that the sister company had with its products.

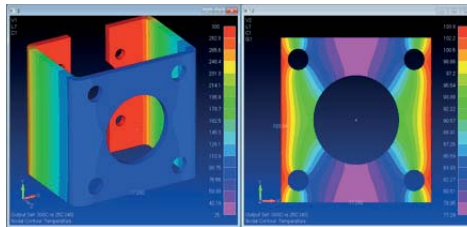

“Use of Femap gives a great boost to our design efficiency and final product quality.”

Xie Ke

General Administrator and Warehouse Manager

Product Automation Center

Beijing Office

Pentair Valves & Controls Corporate China

Siemens PLM Software

Americas +1 314 264 8287

Europe +44 (0) 1276 413200

Asia-Pacific +852 2230 3308

© 2015 Siemens Product Lifecycle Management Software Inc. Siemens and the Siemens logo are registered trademarks of Siemens AG. D-Cubed, Femap, Fibersim, Geolus, GO PLM, I-deas, J.T., NX, Parasolid, Solid Edge, Syncrofit, Teamcenter and Tecnomatix are trademarks or registered trademarks of Siemens Product Lifecycle Management Software Inc. or its subsidiaries in the United States and in other countries. SAP is a trademark or registered trademark of SAP AG in Germany and in several other countries. Windows is a trademark or registered trademark of Microsoft Corporation. All other logos, trademarks, registered trademarks or service marks belong to their respective holders.

43838-Z6 5/15 H

www.siemens.com/plm



A Siemens Partner